



ARISTON

SPARE PARTS EXPLODED VIEW GAS-WALL BOILER ATM. BURNER

Model

HS X - CARES X

R8203464-04 - 18/01/2017

HS X - CARES X

Gas-wall boiler atm. burner

| | | |
|----|---------|-------------------------|
| 1 | 3300897 | HS X 15 CF NG |
| 2 | 3300896 | HS X 24 CF NG |
| 3 | 3300895 | HS X 15 FF NG |
| 3 | 3300946 | HS X 15 FF (RU) |
| 4 | 3300894 | HS X 18 FF NG |
| 5 | 3300893 | HS X 24 FF NG |
| 6 | 3300889 | CARES X 15 CF NG |
| 7 | 3300888 | CARES X 24 CF NG |
| 8 | 3300887 | CARES X 15 FF NG |
| 9 | 3300886 | CARES X 18 FF NG |
| 10 | 3300885 | CARES X 24 FF NG |
| 11 | 3300891 | CARES SYSTEM X 24 CF NG |
| 12 | 3300890 | CARES X SYSTEM 24 FF NG |

| Col | Reference | Model type | Begin | End |
|-----|-----------|------------|-------|-----|
|-----|-----------|------------|-------|-----|

100
200
300
400

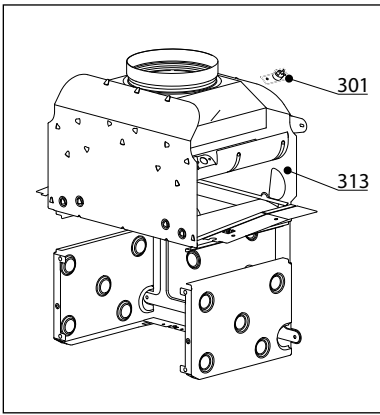

HS X - CARES X

Gas-wall boiler atm. burner

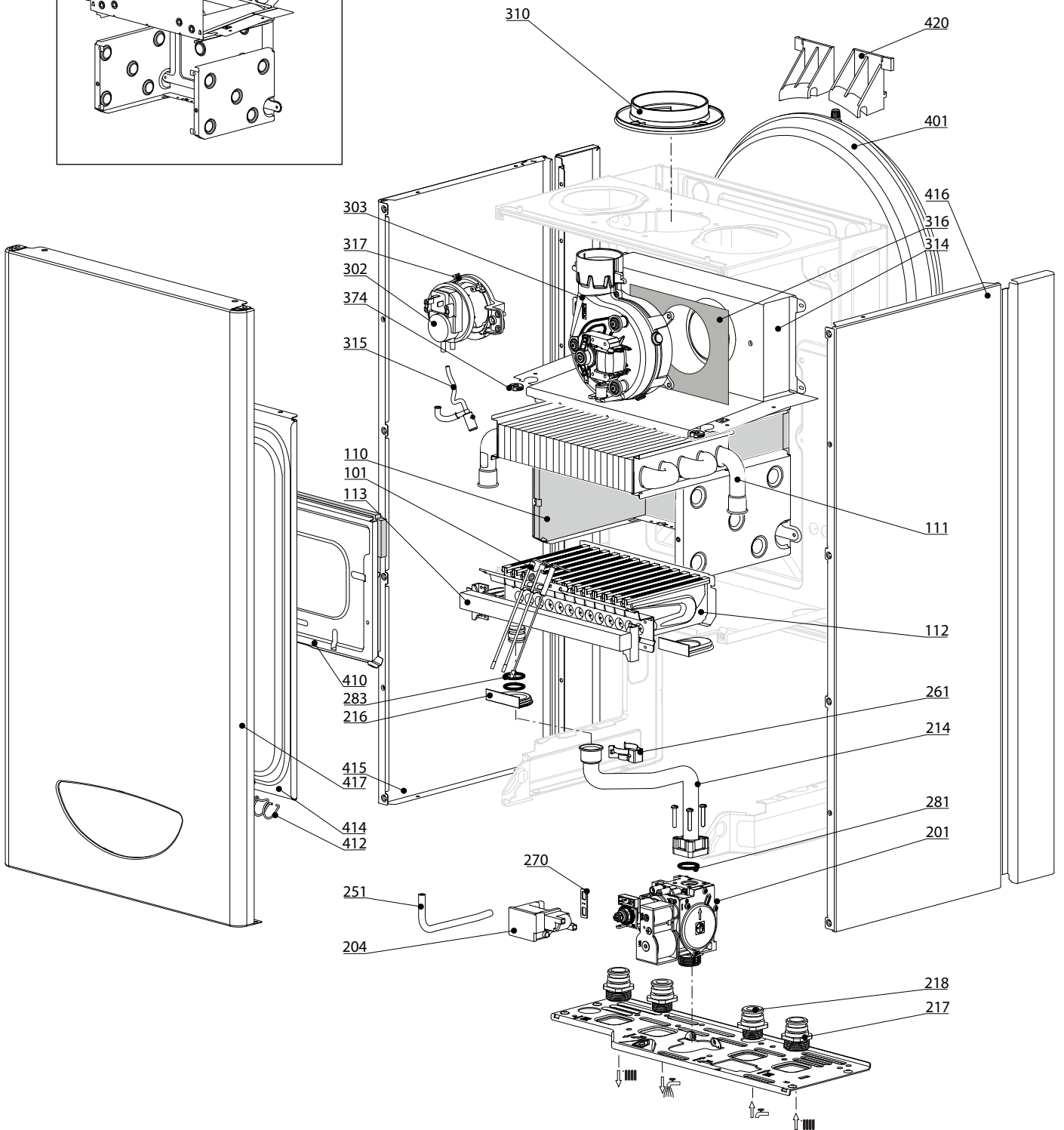

| ☉⇒ | Description | Manf. Pt. N | Type | <div style="display: flex; justify-content: space-between; font-size: small;"> HS X 15 CFHS X 24 CFHS X 15 FFHS X 18 FFHS X 24 FFCARES X 15 CFCARES X 24 CFCARES X 15 FFCARES X 24 FFCARES X SYSTEM 24 CFCARES X SYSTEM 24 FF </div> | | | | | | | | | | | | | | | | | | From | to |
|-------------|---------------------------------------|-------------|------|---|---|---|---|---|---|---|---|---|----|----|----|----|----|----|----|----|----|------|----|
| | | | | 1 | 2 | 3 | 4 | 5 | 6 | 7 | 8 | 9 | 10 | 11 | 12 | 13 | 14 | 15 | 16 | 17 | 18 | | |
| 0100 | ГОРЕЛКА | | | | | | | | | | | | | | | | | | | | | | |
| 0101 | ЭЛЕКТРОДЫ РОЗЖИГА/ИОНИЗАЦИИ | 65115802 | | ● | ● | ● | ● | ● | ● | ● | ● | ● | ● | ● | ● | ● | ● | ● | ● | | | | |
| 0110 | ТЕПЛОИЗОЛЯЦИЯ (КОМПЛЕКТ) | 65104695 | | ● | ● | | | | ● | ● | | | ● | | | | | | | | | | |
| | ТЕПЛОИЗОЛЯЦИЯ (КОМПЛЕКТ) | 65106298 | | | | ● | ● | ● | | | | ● | ● | ● | | | | ● | | | | | |
| 0111 | ОСНОВНОЙ ТЕПЛООБМЕННИК | 65104247 | | ● | ● | | | | ● | ● | | | | | | | | ● | | | | | |
| | ОСНОВНОЙ ТЕПЛООБМЕННИК | 65115065 | | | | ● | ● | ● | | | | ● | ● | ● | | | | ● | | | | | |
| 0112 | ГОРЕЛКА 11NP | 65106294 | | | | ● | ● | ● | | | | ● | ● | ● | | | | ● | | | | | |
| | ГОРЕЛКА 13NP | 60001582 | | ● | ● | | | | ● | ● | | | | | | | | ● | | | | | |
| 0113 | ГАЗОВЫЙ КОЛЛЕКТОР 11 INJ. D:1.32 | 65106302 | G20 | | | ● | ● | ● | | | | ● | ● | ● | | | | ● | | | | | |
| | ГАЗОВЫЙ КОЛЛЕКТОР 13 INJ. D:1.25 | 65104302 | G20 | ● | ● | | | | ● | ● | | | | | | | | ● | | | | | |
| 0200 | ГАЗОВАЯ ЧАСТЬ | | | | | | | | | | | | | | | | | | | | | | |
| 0201 | ГАЗОВЫЙ КЛАПАН | 65115771 | | ● | ● | ● | ● | ● | ● | ● | ● | ● | ● | ● | ● | ● | ● | ● | ● | | | | |
| 0204 | БЛОК РОЗЖИГА | 65115791 | | ● | ● | ● | ● | ● | ● | ● | ● | ● | ● | ● | ● | ● | ● | ● | ● | | | | |
| 0214 | ПАТРУБОК (ГАЗОВЫЙ КЛАПАН/ГОРЕЛКА) | 65115772 | | ● | ● | ● | ● | ● | ● | ● | ● | ● | ● | ● | ● | ● | ● | ● | ● | | | | |
| 0216 | УПЛОТНЕНИЕ | 60000624 | | ● | ● | ● | ● | ● | ● | ● | ● | ● | ● | ● | ● | ● | ● | ● | ● | | | | |
| 0217 | СОЕДИНЕНИЕ (3/4") | 65114929 | | ● | ● | ● | ● | ● | ● | ● | ● | ● | ● | ● | ● | ● | ● | ● | ● | | | | |
| 0218 | СОЕДИНЕНИЕ (1/2") | 65114930 | | ● | ● | ● | ● | ● | ● | ● | ● | ● | ● | ● | ● | ● | ● | ● | ● | | | | |
| 0251 | ТРУБКА EPDM | 65115773 | | ● | ● | ● | ● | ● | ● | ● | ● | ● | ● | ● | ● | ● | ● | ● | ● | | | | |
| 0261 | КЛИПСА | 60001861 | | ● | ● | ● | ● | ● | ● | ● | ● | ● | ● | ● | ● | ● | ● | ● | ● | | | | |
| 0270 | ПРОКЛАДКА БЛОКА РОЗЖИГА | 574279 | | ● | ● | ● | ● | ● | ● | ● | ● | ● | ● | ● | ● | ● | ● | ● | ● | | | | |
| 0281 | O-КОЛЬЦО 22.22X2.62 | 65104304 | | ● | ● | ● | ● | ● | ● | ● | ● | ● | ● | ● | ● | ● | ● | ● | ● | | | | |
| 0283 | O-КОЛЬЦО 17.17X1.78 | 65104303 | | ● | ● | ● | ● | ● | ● | ● | ● | ● | ● | ● | ● | ● | ● | ● | ● | | | | |
| 0319 | ДИАФРАГМА | 60001598 | | ● | ● | ● | ● | ● | ● | ● | ● | ● | ● | ● | ● | ● | ● | ● | ● | | | | |
| 0300 | ДЫМОУДАЛЕНИЕ И ВОЗДУХОПОДАЧА | | | | | | | | | | | | | | | | | | | | | | |
| 0301 | ТЕРМОСТАТ 75-65°C | 999539 | | ● | ● | ● | ● | ● | ● | ● | ● | ● | ● | ● | ● | ● | ● | ● | ● | | | | |
| 0302 | ПНЕВМОРЕЛЕ 50 Pa | 65104671-01 | | | | ● | ● | ● | | | | ● | ● | ● | | | | ● | | | | | |
| 0303 | ВЕНТИЛЯТОР 24 KW | 65115813 | | | | ● | ● | ● | | | | ● | ● | ● | | | | ● | | | | | |
| 0310 | ПАТРУБОК ЗАБОРА ВОЗДУХА | 65115914 | | | | ● | ● | ● | | | | ● | ● | ● | | | | ● | | | | | |
| 0313 | СТАБИЛИЗАТОР ТЯГИ 24 CF | 65104218 | | ● | ● | | | | ● | ● | | | | | | | | ● | | | | | |
| 0314 | КАМЕРА СГОРАНИЯ 24 FF | 65115800 | | | | ● | ● | ● | | | | ● | ● | ● | | | | ● | | | | | |
| 0315 | КОНДЕНСАТООТВОДЧИК | 65105349 | | | | ● | ● | ● | | | | ● | ● | ● | | | | ● | | | | | |
| 0316 | ТЕПЛОИЗОЛЯЦИЯ ВЕНТИЛЯТОРА | 65104305 | | | | ● | ● | ● | | | | ● | ● | ● | | | | ● | | | | | |
| 0317 | КРОНШТЕЙН ПНЕВМОРЕЛЕ | 65115812 | | | | ● | ● | ● | | | | ● | ● | ● | | | | ● | | | | | |
| 0374 | УПЛОТНЕНИЕ ДЛЯ КАБЕЛЯ | 60000716 | | ● | ● | ● | ● | ● | ● | ● | ● | ● | ● | ● | ● | ● | ● | ● | ● | | | | |
| 0400 | КОРПУС | | | | | | | | | | | | | | | | | | | | | | |
| 0401 | РАСШИРИТЕЛЬНЫЙ БАК 8 Л | 65104261 | | ● | ● | ● | ● | ● | ● | ● | ● | ● | ● | ● | ● | ● | ● | ● | ● | | | | |
| 0410 | ПАНЕЛЬ КАМЕРЫ СГОРАНИЯ | 65104240 | | ● | ● | | | | ● | ● | | | | | | | | ● | | | | | |
| | ПАНЕЛЬ КАМЕРЫ СГОРАНИЯ | 65106296 | | | | ● | ● | ● | | | | ● | ● | ● | | | | ● | | | | | |
| 0414 | Герметизирующая крышка | 65105678-02 | | | | ● | ● | ● | | | | ● | ● | ● | | | | ● | | | | | |
| 0416 | ПАНЕЛЬ КОРПУСА (ЛЕВАЯ + ПРАВАЯ) БЕЛАЯ | 65115804 | | ● | ● | ● | ● | ● | ● | ● | ● | ● | ● | ● | ● | ● | ● | ● | ● | | | | |
| 0417 | ПАНЕЛЬ КОРПУСА (ПЕРЕДНЯЯ) | 65115823 | | | | ● | ● | ● | | | | ● | ● | ● | | | | ● | | | | | |
| | ПАНЕЛЬ КОРПУСА (ПЕРЕДНЯЯ) | 65115824 | | ● | ● | ● | ● | ● | | | | ● | ● | ● | | | | ● | | | | | |
| 0420 | КРОНШТЕЙН РАСШИРИТЕЛЬНОГО БАКА | 65104696 | | ● | ● | ● | ● | ● | ● | ● | ● | ● | ● | ● | ● | ● | ● | ● | ● | | | | |

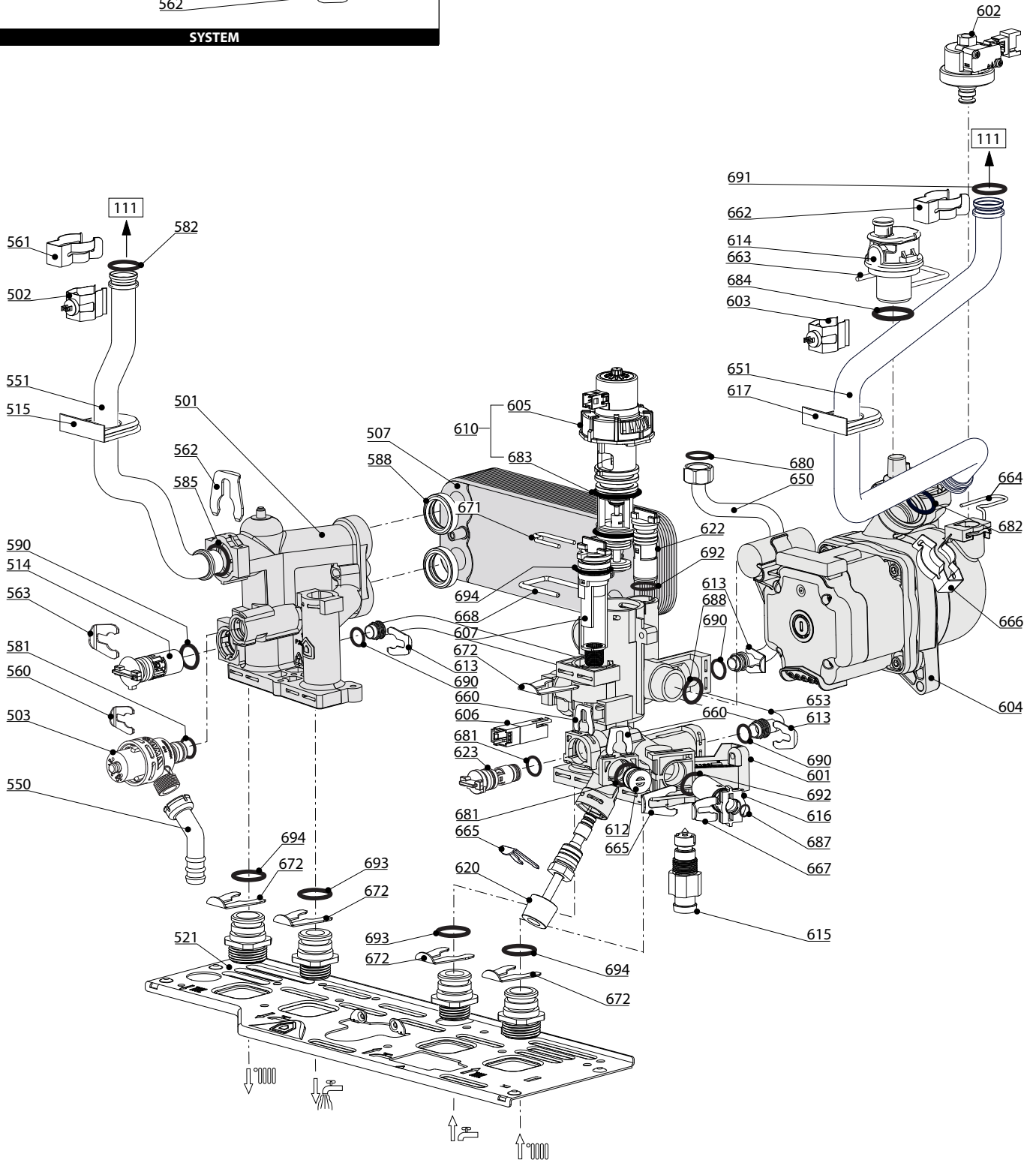
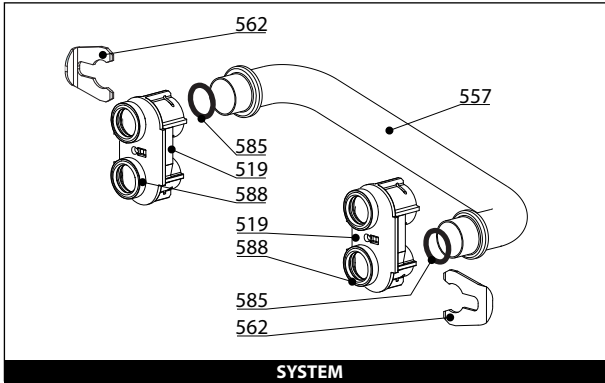

800

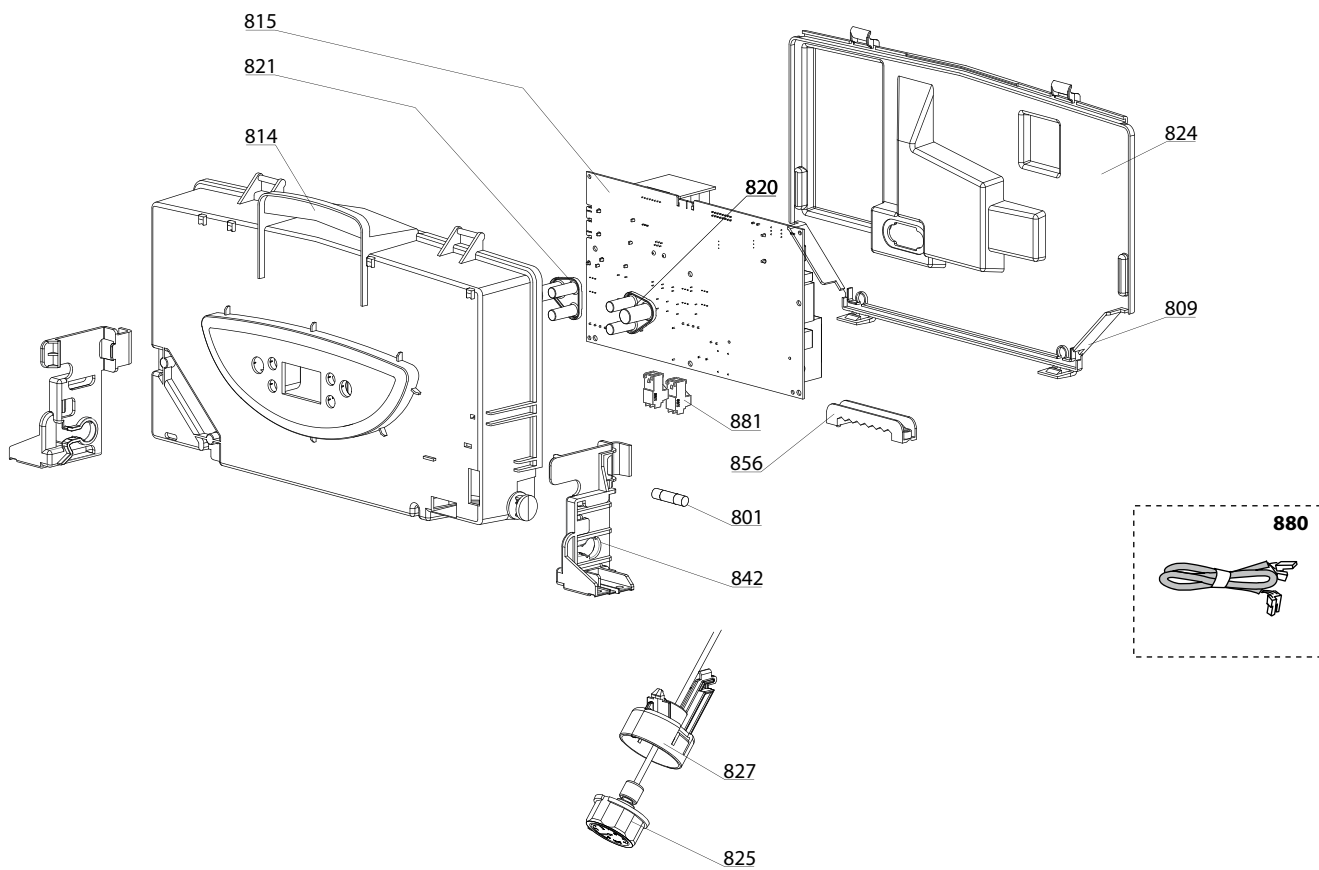

900

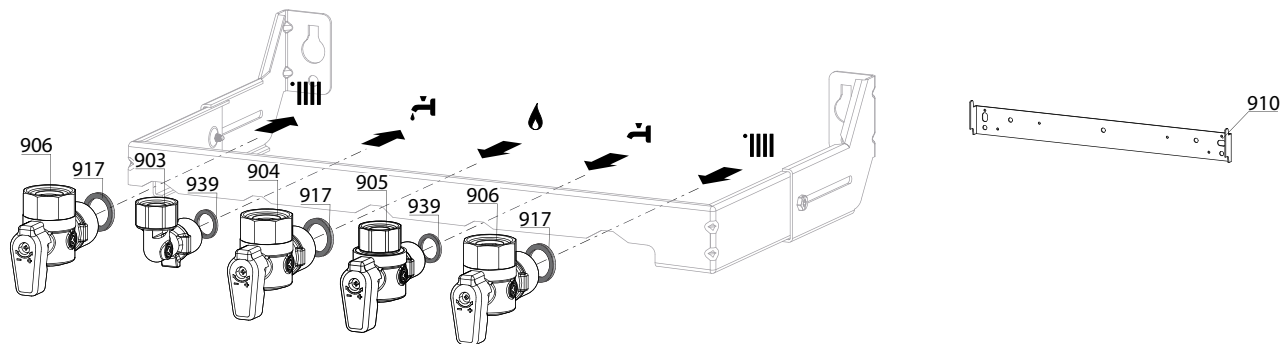

| ☉⇒ | Description | Manf. Pt. N | Type | <div style="display: flex; justify-content: space-between; font-size: small;"> HS X 15 CF HS X 24 CF HS X 15 FF HS X 18 FF HS X 24 FF CARES X 15 CF CARES X 24 CF CARES X 15 FF CARES X 18 FF CARES X 24 FF CARES X SYSTEM 24 CF CARES X SYSTEM 24 FF </div> | | | | | | | | | | | | | | From | to |
|-------------|-------------------------------------|-------------|------|--|---|---|---|---|---|---|---|---|----|----|----|----|----|------|----|
| | | | | 1 | 2 | 3 | 4 | 5 | 6 | 7 | 8 | 9 | 10 | 11 | 12 | 13 | 14 | | |
| 0800 | ЭЛЕКТРИЧЕСКАЯ ЧАСТЬ | | | | | | | | | | | | | | | | | | |
| 0809 | ЗАГЛУШКА | 998382 | | ● | ● | ● | ● | ● | ● | ● | ● | ● | ● | | | | | | |
| 0814 | КРЫШКА ПАНЕЛИ УПРАВЛЕНИЯ (ПЕРЕДНЯЯ) | 65115818 | | | | | | | ● | ● | ● | ● | ● | | | | | | |
| | КРЫШКА ПАНЕЛИ УПРАВЛЕНИЯ (ПЕРЕДНЯЯ) | 65115819 | | ● | ● | ● | ● | ● | | | | | | | | | | | |
| 0815 | ОСНОВНАЯ ПЛАТА | 65115782 | | ● | ● | ● | ● | ● | ● | ● | ● | ● | ● | | | | | | |
| 0820 | КНОПКА УПРАВЛЕНИЯ (ПРАВАЯ) | 65153181 | | ● | ● | ● | ● | ● | ● | ● | ● | ● | ● | | | | | | |
| 0821 | КНОПКА УПРАВЛЕНИЯ (ЛЕВАЯ) | 65153180 | | ● | ● | ● | ● | ● | ● | ● | ● | ● | ● | | | | | | |
| 0824 | КРЫШКА ПАНЕЛИ УПРАВЛЕНИЯ (ЗАДНЯЯ) | 65115820 | | ● | ● | ● | ● | ● | ● | ● | ● | ● | ● | | | | | | |
| 0825 | МАНОМЕТР | 65114200 | | ● | ● | ● | ● | ● | ● | ● | ● | ● | ● | | | | | | |
| 0827 | КРОНШТЕЙН МАНОМЕТРА | 65115809 | | ● | ● | ● | ● | ● | ● | ● | ● | ● | ● | | | | | | |
| 0842 | БОКОВОЙ ФИКСАТОР ПАНЕЛИ УПРАВЛЕНИЯ | 65115811 | | ● | ● | ● | ● | ● | ● | ● | ● | ● | ● | | | | | | |
| 0856 | ЗАЖИМ ДЛЯ КАБЕЛЯ | 65103377 | | ● | ● | ● | ● | ● | ● | ● | ● | ● | ● | | | | | | |
| 0880 | КАБЕЛЬ 3-Х ХОДОВОГО КЛАПАНА | 65115790 | | ● | ● | ● | ● | ● | ● | ● | ● | ● | ● | | | | | | |
| | КАБЕЛЬ 3-Х ХОДОВОГО КЛАПАНА | 65115937 | | | | | | | | | | | ● | ● | | | | | |
| | КАБЕЛЬ ЭЛЕКТРОДА ИОНИЗАЦИИ | 60001883 | | ● | ● | ● | ● | ● | ● | ● | ● | ● | ● | | | | | | |
| | КАБЕЛЬ ЗАЗЕМЛЕНИЯ | 65104286 | | ● | ● | ● | ● | ● | ● | ● | ● | ● | ● | | | | | | |
| | КАБЕЛЬ ПИТАНИЯ 240V | 60001619 | | ● | ● | ● | ● | ● | ● | ● | ● | ● | ● | | | | | | |
| | КАБЕЛЬ ДАТЧИК ТЕМП. - ПНЕВМОРЕЛЕ | 65115789 | | ● | ● | ● | ● | ● | ● | ● | ● | ● | ● | | | | | | |
| | КАБЕЛЬ НАСОСА 1V WILO | 65105081 | WILO | ● | ● | ● | ● | ● | ● | ● | ● | ● | ● | | | | | | |
| 0881 | КОННЕКТОР 2P | 65111933 | | ● | ● | ● | ● | ● | ● | ● | ● | ● | ● | | | | | | |
| | КОННЕКТОР 3P (x5) | 65111934-01 | | ● | ● | ● | ● | ● | ● | ● | ● | ● | ● | | | | | | |
| 0900 | МОНТАЖНЫЕ АКСЕССУАРЫ | | | | | | | | | | | | | | | | | | |
| 0903 | ПАТРУБОК ПОДКЛЮЧЕНИЯ ГВС | 60000891 | | ● | ● | ● | ● | ● | ● | ● | ● | ● | ● | | | | | | |
| 0904 | КРАН ГАЗА | 60000898 | | ● | ● | ● | ● | ● | ● | ● | ● | ● | ● | | | | | | |
| 0905 | КРАН ХОЛОДНОЙ ВОДЫ | 60000894 | | ● | ● | ● | ● | ● | ● | ● | ● | ● | ● | | | | | | |
| 0906 | КРАН ПОДАЧИ/ВОЗВРАТА ТЕПЛОНОСИТЕЛЯ | 60000885 | | ● | ● | ● | ● | ● | ● | ● | ● | ● | ● | | | | | | |
| 0910 | КРОНШТЕЙН | 60000625 | | ● | ● | ● | ● | ● | ● | ● | ● | ● | ● | | | | | | |
| 0917 | ПЛОСКАЯ ПРОКЛАДКА D:24-17-1.5 | 60061855-19 | | ● | ● | ● | ● | ● | ● | ● | ● | ● | ● | | | | | | |
| 0939 | ПЛОСКАЯ ПРОКЛАДКА D:16.5-11-1.5 | 60061854-14 | | ● | ● | ● | ● | ● | ● | ● | ● | ● | ● | | | | | | |

LIST OF THE ABBREVIATIONS

| | |
|-------------|--|
| HW | : Hot water. |
| CW | : Cold water. |
| C | : Ceramic resistance (normal heating). |
| Ca | : Ceramic resistance (accelerated heating) |
| TP | : Immersion heater. |
| 1F | : With fittings. |
| 2F | : Without fittings. |
| 3F | : With fittings and another outlet connection. |
| AMI | : With mixing valve. |
| SMI | : Without mixing valve. |
| PUISS | : Power of th appliance. |
| PN | : Appliance with normal pression. |
| LP | : Appliance with low pression. |
| PV | : Appliance with variable power. |
| PF | : Appliance with fixed power. |

IDENTIFICATION PLATE

SERIAL NUMBER

| | | |
|-----------------------------|---------------------------|-----------------------------------|
| 10 Characters : | 04 05 125 011 | |
| | | Sequential number |
| | | Manufacturing day |
| | | Year of manufacture |
| 11 Characters : | 1 95 065004 - 31 | |
| Month of manufacture : | | Technical number of the appliance |
| from 1 to 9 → Jan. to Sep., | | Sequential number |
| O → Oct., N → Nov., | | Year of manufacture |
| D → Dec. | | |
| 19 Characters : | 08 05 0013199 900640031 | |
| Year of manufacture | | Product reference |
| Month of manufacture | | Sequential number |
| 20 Characters : | 3675007 XX 2 07 070 00315 | |
| Product reference | | Sequential number |
| Millenium of manufacture | | Manufacturing day |
| | | Year of manufacture |
| 21 Characters : | 3675007 XX 07 070 0000315 | |
| Product reference | | Sequential number |
| Year of manufacture | | Manufacturing day |